

Specifications

DESCRIPTION

- Thermostatic mixing valve, with adjustable temperature control cartridge
- All brass construction with vandal resistant cap
- 1/2" FNPT connections with 3/8" compression adapters
- Hot and cold check valves prevent possible backflow on water supply inlets
- Stainless steel internal strainer protect against line trash

OPERATION

- Factory preset at 105°F (40°C)
- Adjustable from 95°F (35°C) to 120°F (49°C), with a $\pm 3.6^\circ\text{F}$ ($\pm 2^\circ\text{C}$) temperature accuracy
- Working pressure: maximum=125 psi (861 kPa), minimum=20 psi (138 kPa)
- Flow rate at 45 psi (310 kPa) =4.9 gpm (18.6 L/min), minimum flow rate=0.35 gpm (1.3 L/min)
- Cold water supply=39° (4°C) to 80°F (27°C), hot water supply=120° (49°C) to 180°F (82°C)

CARTRIDGE

- Paraffin based thermostatic engine

STANDARDS

- Third party certified to meet ASSE 1070/ASME A112.1070/CSA B125.70 and all applicable requirements referenced therein
- NSF 372 certified

WARRANTY

- 5 year limited warranty

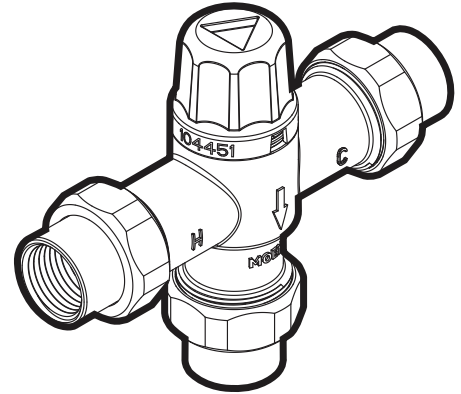

**Adjustable Temperature
Thermostatic Mixing Valve**

MODEL: 104451

